

1029GNH 10.1" IP67 Sunlight Readable Optical Bonded Capacitive Touchscreen LCD Monitor w/ HDMI, DVI, VGA & AV Inputs



Description

The 1029GNH, built from the chassis of the extremely popular 1029CNH IP65 dust/splash proof **industrial-grade display**, brings ruggedization to another level. Not only is this **10.1" industrial display monitor IP67 and NEMA6P dust and water proof**, it is also **optically bonded** for better viewing clarity, as well as resistance to any environmental humidity that could cause fogging or condensation in certain situations. The cabling and connectors are also water tight, giving this monitor further durability and versatility in any environmental situation. This 10.1" industrial display monitor unit is available without Optical Bonding and with an IP65 rating in the 1029CNH.

The 1029GNH offers all of the innovation and inputs as our 1020 series models along with a **capacitive touchscreen panel**. Capacitive sensing provides a more responsive touch interface than resistive touch. It achieves this by using the capacitance of human skin to detect the proximity or position of the input. Proximity sensing allows the touch interaction to work even if protective glass or coating is used over the **10.1" industrial display**. The touch panel is optically bonded to the LCD panel, eliminating the air gap between the two, increasing clarity, contrast, and durability. Further, because the unit is water tight and air tight, ambient humidity will not affect the clarity or viewability because of the optical bonding.

Why do our products outlast others in extreme conditions? Why do our products have a wider temperature range and a wider voltage input range? It is because our mission is to offer our customers the best products for any situation. By utilizing high grade components, this display is

perfect for industrial, in-car computing applications or any other applications where a small, durable, environmentally rugged display is required, including but not limited to:

- **Transportation** - Marine, Air, Heavy Vehicles, Mining, Weigh Stations, Fleet Management, Telematics, In-Car Computing, Public Transit, Cargo
- **System Integration** - Machinery Controls, Factory Automation, Environmental Monitoring, Home Automation, Military, Smart Home
- **Point of Sale** - Hospitality, Digital Signage, Self-Service Kiosks, Outdoor Kiosks and Signage, Casino
- **Data Monitoring** - Cloud, IoT, Medical, Logistics, Inventory Management, Oil & Gas/Utilities, Law Enforcement, Broadcasting, Veterinary, First Person View

Features

- IP67 / NEMA6P Rated Water and Dust Resistance
- 1,000NIT Sunlight Readable with Long Life LED Backlight
- Automatic Backlight Adjustment through Built-in Ambient Light Sensor
- Projected Capacitive Multi-Touch Touchscreen (USB)
- Anti-Reflective and Anti-Fingerprint Coating
- Plug-N-Play with Windows 7 and up and Android devices (Downloadable drivers for other OS)
- Multi-Monitor Touchscreen Support
- HDMI Input x 1 (HDCP), VGA Input (15 pin D-SUB) x 1 & Video Input x 2
- DVI Input through included DVI to HDMI Adaptor
- Audio Input x 3 / Built-In Waterproof Speaker
- 1024x600 Native Resolution, 16x9 Aspect Ratio
- Solid Capacitors for Improved Durability
- High Performance Image and Video Signal Processor
- **AISS** - Advanced Image-Scaling and Shaping
- Last Input and Power Setting Memory
- IR Remote Control
- Auto Power-On upon signal detection
- Mirror and Vertical Image Flip
- Function to Disable Front Button(s) and On Screen Text
- AV2 Auto Switching for Backup Camera
- 360° Copper Monitor Stand or U-Shape Mount
- VESA 75mm Mounting Holes
- 26-Pin Heavy-Duty Connector with Connector Locking
- Ruggedized Aluminum Casing
- Supports 9V DC ~ 36V DC
- "E" Mark Certified for Automotive use
- FCC, CE, E13 Certification
- IK08 Impact Resistant
- ROHS Compliant
- 24 Month Warranty
- 30 Day No dead Pixel Guarantee

Function Diagram

How does it work?

- Connect the included cable to the Monitor
- Connect the connectors to your devices
- Install Touch Screen Driver



[CNH Series]

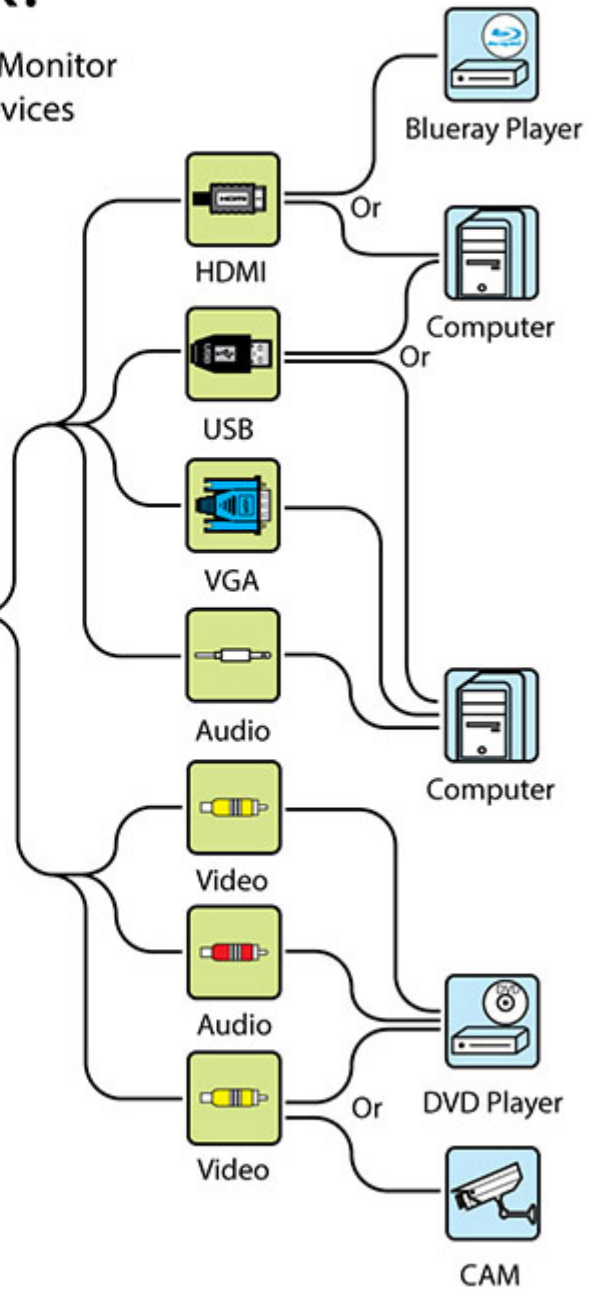
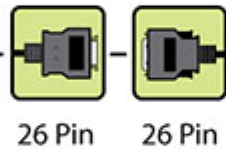

XENARC
TECHNOLOGIES

Package Contents

- Copper Monitor Stand or U-Shape Mount or Panel Mount Bracket
- 5M Power Lead (IP67) or AC Adaptor (IP65) or Cigarette Lighter Car Adaptor (IP65)
- 1.8 Meter Cable or 5 Meter Cable or 2 Feet Cable with only HDMI & USB, or 2 Feet Cable with only VGA & USB

Specification

- Screen Size: Diagonal 10.1" (16:9)
- Physical Resolution: 1024 (H) x 600 (V) WXGA
- Supported Resolution: 640 x 480 ~ 1920 x 1080
- Dot Resolution: 3072 x 600 = 1,843,200 (dots)
- Brightness: 1000 cd/m²
- Contrast Ratio: 600:1
- Viewing Angle: 140° Horizontal, 120° Vertical
- Response Time (Tr/Tf): 5/20ms (Typ.)
- Touch Screen Interface: USB port
- Operating Voltage Range: DC 9V ~ 36V
- Power Supply: DC 12V
- Power Consumption: ? 20W
- Operating Temperature: -4°F ~ 158°F (-20°C ~ 70°C)
- Storage Temperature: -22°F ~ 176°F (-30°C ~ 80°C)
- Vibration: Operating Random Vibration Test (5-500Hz, 1.0Grms), IEC 60068-2-64 standard
- Shock: Operating Shock Test, 10G peak acceleration (11ms duration), IEC 60068-2-27 standard
- MTBF (Mean Time Between Failures): > 55,000 Hours
- Dimension (mm): 265.7W x 178.2H x 32.2D
- Weight (lb): 3.64